

Gas filled // Version for diesel engines



Type 1312

Your advantages

Series	6312 / 8312 / 1312 / 6372 / 8372 / 1372
	<ul style="list-style-type: none"> • Vibration-resistant due to highly viscous silicone filling • Suitable for outdoor use - closed system (IP65) • Without electrical auxiliary power

Technical data

Type	6312	8312	1312	6372	8372	1372
Version	Rigid connection with neck tube					
Nominal size	Ø 63 mm	Ø 80 mm	Ø 100 mm	Ø 63 mm	Ø 80 mm	Ø 100 mm
Display ranges according to EN 13190	0...100 °C 0...120 °C 0...160 °C 0...250 °C 50...650 °C					
Accuracy according to EN 13190	Class 1					
Medium / Application area	Liquid and gaseous media					
Immersion tube connection	Bottom			Central back		
Immersion tube length	Between 63...400 mm					
Immersion tube diameter	Ø 10 (not NS 100 mm), 12 or 13 mm					
Process connection	Connection types: A, AK					
Nominal pressure	Max. 25 bar					
Measuring system	Nitrogen filled					
Degree of protection according to EN 60529	IP65					
Medium temperature	See selected display range					
Ambient temperature	-20...60 °C (only indoors)					
Storage temperature	-40...60 °C					
Nominal service temperature (EN 13190)	23 °C ±2 °C					
Approvals						

Options

For type	On request
6312 / 8312 / 1312 / 6372 / 8372 / 1372	Other display ranges and / or special scales, e.g. double scale °C / °F. Versions with union nut

Type 6312

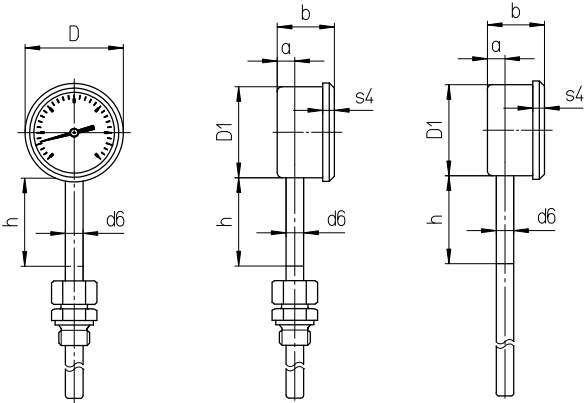

Type 8312 and 1312

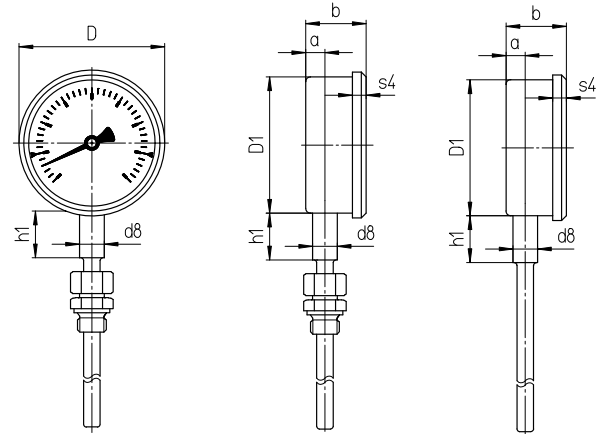

Type 6372, 8372 and 1372

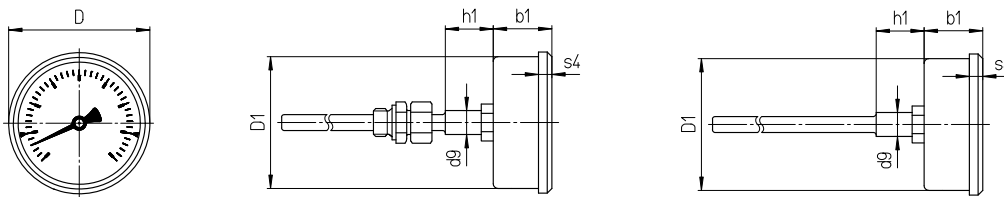

Dimensions [mm]											Weight [kg]
NS	a	b	D	D1	d6	d8	d9	h	h1	s4	
63	12	39	67	62	12	18	18	60	34	8	0.33
80	15	42	86	79	12	18	18	60	34	8	0.50
100	15	43	106	99	12	18	18	60	34	10	0.70

This information is provided as an example and relates to the version with connection type A Ø 10 mm and immersion tube length 200 mm.

Material	
Housing	Crimped-on ring, Stainless steel 1.4301 filled with silicone oil (highly viscous)
Window	Instrument glass
Pointer movement	German silver / brass
Dial	Aluminium white with black scale markings
Pointer	Aluminium black
Material in contact with media	
Process connection	Steel
Immersion tube	Stainless steel 1.4571

Standard connection types // Immersion tube // for type 6312 - 1372

Connection type A

Plain immersion tube, universally usable

Connection type AK [mm]

With adjustable compression fitting

G	SW1	i	Lk
G½ B	27	14	35
G¾ B	32	16	37
M20 x 1.5	27	14	35
M27 x 2	32	16	37

Stem diameter [mm]

Ø d	SW2
10	19
12	22
13	24

Connection type A

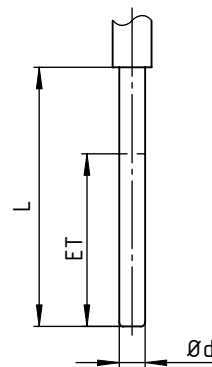

Connection type AK

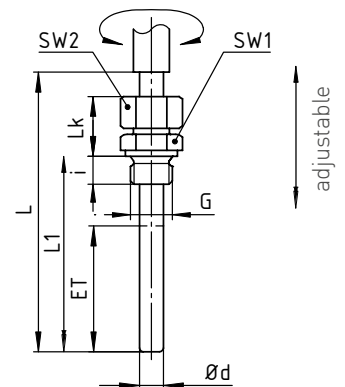

Active length (ET) and minimum feasible immersion tube length

Connection type	Length [mm]	
	ET	Lmin
A	80	150
AK	80	150

The minimum length L_{min} / l_{1min} of the immersion tube is the shortest possible immersion tube length for a given active length ET (bulb) and connection type. The active length ET of the immersion tube (bulb) must be fully immersed in the substance to be measured in order to obtain measurements corresponding to the stated accuracy class. The maximum realisable stem length is 2.5 m.

Order code										
Nominal size										
63 mm	Z 63									
80 mm	Z 83									
100 mm	Z 13									
Immersion tube connection										
Bottom		12								
Central back		72								
Connection type										
Connection type A, Plain immersion tube								A		
Connection type AK, adjustable compression fitting								M		
Display range										
0...100 °C								10		
0...120 °C								12		
0...160 °C								16		
0...250 °C								25		
50...650 °C								56		
Temperature unit										
Celsius °C*								1		
Immersion tube length l_1	Nominal length $L = l_1 + 45$ mm									
100 mm	145 mm							100		
135 mm	180 mm							135		
160 mm	205 mm							160		
200 mm	245 mm							200		
250 mm	295 mm							250		
300 mm	345 mm							300		
400 mm	445 mm							400		
Process connection										
Without - Plain immersion tube type A									0	
G $\frac{1}{2}$									2	
G $\frac{3}{4}$									3	
$\frac{1}{2}$ NPT									B	
$\frac{3}{4}$ NPT									C	
M20 x 1.5									7	
Material process connection										
Without - Plain immersion tube type A									0	
Steel									2	
Immersion tube diameter										
10 mm (only for NS 63 and NS 80 mm)									3	
12 mm									4	
13 mm									6	
Example order number	Z	63	12	A	10	1	100	0	0	3

* Double scale °C and °F available on request.